

OPTIONAL EQUIPMENT

silentlab



Do you have an eye for design and refuse to settle for less than top quality? Our quiet zones compatible accessories has been carefully designed for the discerning client. You can choose from a wide variety of furniture and leading-edge technologies to take your work environment to the next level.



AV CONNECTION SET

silentlab



Do you have a client or a team member on the other side of the world? Our soundproof office pods come fully equipped for video conferencing, making it easy to install your own devices. This ensures a video call experience that comes remarkably close to meeting in person.

OPTIONAL
EQUIPMENT



AV CONNECTION SET

The AV connection set is seamlessly integrated during production. Combined with excellent soundproofing, modern features, and superior audio and video quality, it creates the perfect environment for professional meetings.

The FOCUS acoustic pod is equipped with an ergonomic arm integrated into the table, designed to hold a monitor.



The AV connection set in the SUMMIT⁴, SUMMIT⁶, and SUMMIT⁸ acoustic pods includes a VESA mount for attaching a TV to the rear glass wall and a pair of sockets for power connection.



All intellectual property rights („Rights“), whether registered or not, relating to any content, texts, photographs, images, logos, instructions, designs, technical solutions, etc. („Content“) are the property of SilentLab s.r.o. („Owner“) and any interference with these Rights to any Content or part thereof without the prior express and written consent of the Owner is not permitted. Any use of the Content not expressly authorized in writing in advance, with the exception of internal and non-commercial use of the unmodified Content for the purposes of the customer's own order, is considered an infringement of the Owner's Rights. In particular (not exclusively), any reproduction, change, addition, merger or other modification of the Content is prohibited without the prior express written consent of the Owner.

The final product configuration may differ from the versions shown in the photographs.
SilentLab®, MICROOFFICE® and their logos are registered trademarks of SilentLab s.r.o. All MICROOFFICE products are patent pending.

version 2025.1

HEIGHT ADJUSTABLE STOOL

silentlab



Stool with square seat of adjustable height. Swivel seat upholstered with chenille fabric and foam padding for greater comfort. Thick cylindrical steel foot with rectangular footrest with matt black finish. Available in different finishes and/or colours. To combine them or choose your favorite.

FURNITURE





Technical details

dimensions	standard height 1030 mm minimum adjustable height 820 mm maximum adjustable height 1030 mm width 445 mm depth 455 mm
weight	7,05 kg
material	70% steel, 10% fabric, 10% foam (polyuretan), 9% E0 low-emission plywood, 1% plastic
color	black

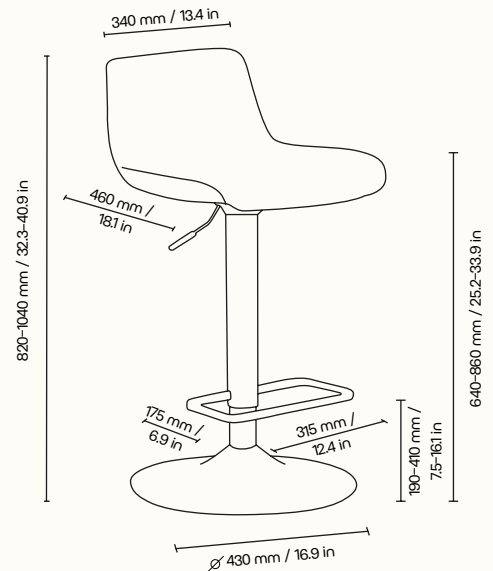

All intellectual property rights („Rights“), whether registered or not, relating to any content, texts, photographs, images, logos, instructions, designs, technical solutions, etc. („Content“) are the property of SilentLab s.r.o. („Owner“) and any interference with these Rights to any Content or part thereof without the prior express and written consent of the Owner is not permitted. Any use of the Content not expressly authorized in writing in advance, with the exception of internal and non-commercial use of the unmodified Content for the purposes of the customer's own order, is considered an infringement of the Owner's Rights. In particular (not exclusively), any reproduction, change, addition, merger or other modification of the Content is prohibited without the prior express written consent of the Owner.

The final product configuration may differ from the versions shown in the photographs.
SilentLab®, MICROOFFICE® and their logos are registered trademarks of SilentLab s.r.o. All MICROOFFICE products are patent pending.

version 2025.2

WHITEBOARD

silentlab



It serves as a helpful tool during meetings or brainstorming sessions. The board is made of lacquered sheet metal and functions as a practical accessory for the exterior panels of acoustic pods.



OPTIONAL
EQUIPMENT



Technical details

basic dimensions (w × h × d)	970 × 1130 × 2 mm / 38.2 × 44.5 × 0.08 in
material	lacquered sheet metal
installation	wooden hooks

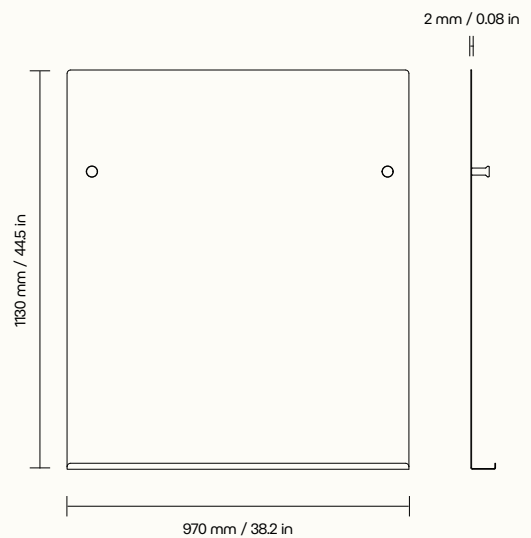

All intellectual property rights („Rights“), whether registered or not, relating to any content, texts, photographs, images, logos, instructions, designs, technical solutions, etc. („Content“) are the property of SilentLab s.r.o. („Owner“) and any interference with these Rights to any Content or part thereof without the prior express and written consent of the Owner is not permitted. Any use of the Content not expressly authorized in writing in advance, with the exception of internal and non-commercial use of the unmodified Content for the purposes of the customer’s own order, is considered an infringement of the Owner’s Rights. In particular (not exclusively), any reproduction, change, addition, merger or other modification of the Content is prohibited without the prior express written consent of the Owner.

The final product configuration may differ from the versions shown in the photographs.
SilentLab®, MICROOFFICE® and their logos are registered trademarks of SilentLab s.r.o. All MICROOFFICE products are patent pending.

version 2025.1